

Outwash Test Results for a Single Rotor in Hover

Ethan Romander

Alyna Anderson, Haley Cummings, Michelle Dominguez,
Avraham Gileadi, Kristen Kallstrom, Michael Radotich, Alex Sheikman,
Dorsa Shirazi, Neal Smith, Gloria Yamauchi

VFS 82nd Annual Forum and Technology Display
West Palm Beach, FL
May 7, 2026



Overview



- Introduction
- Rotor and Instrumentation
- Test Conditions and Procedure
- Sample Results
- Summary
- Future Work



Introduction

- Outwash results when rotor downwash interacts with a ground plane
- Historically of interest to armed forces
 - Risk of damage to personnel and equipment
 - Contributes to degraded visual environment
- Recent eVTOL industry and government regulatory interest
 - Safety of civilian passengers and crew
 - Novel vertiport environment
- Challenges
 - High disk loading
 - Incomplete understanding of multirotor interactions

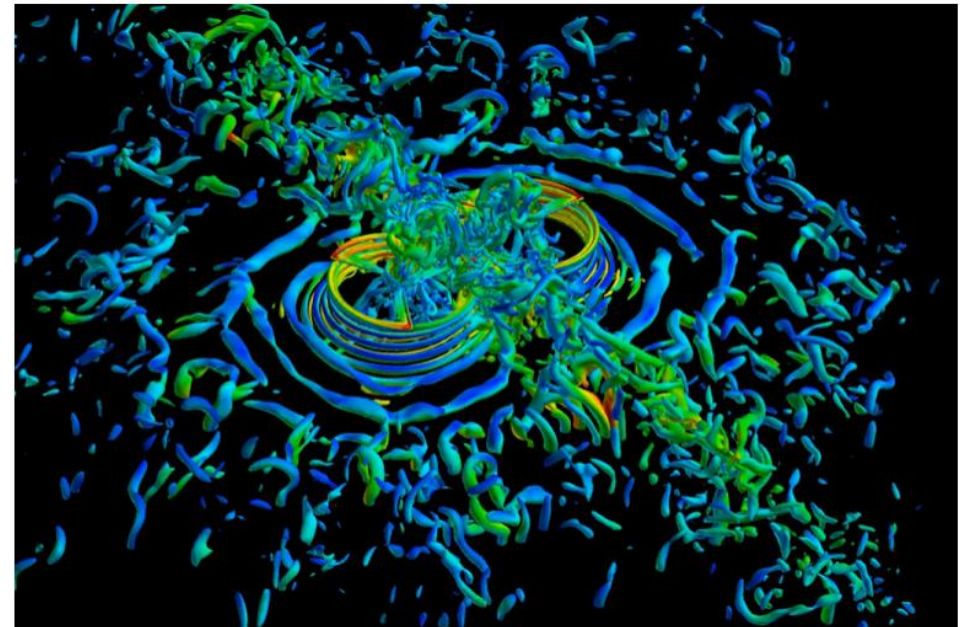
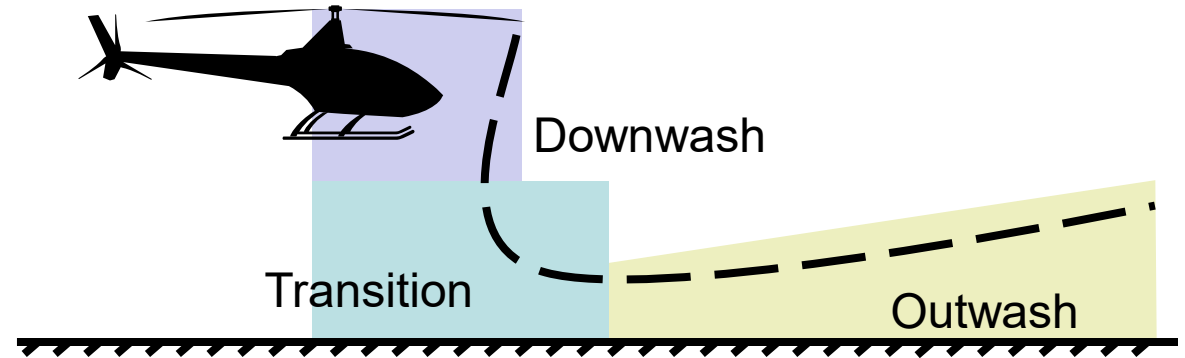



Gather high spatial-resolution outwash velocity measurements on single and multi-rotor configurations for tool validation

Approach



- Phase 1—Single Rotor
 - Develop hardware and measurement technique
- Phase 2—Dual Rotor
 - Examine the effects of interacting rotor wakes on outwash
- Phase 3—Quad Rotor
 - Explore outwash characteristics unique to eVTOL aircraft

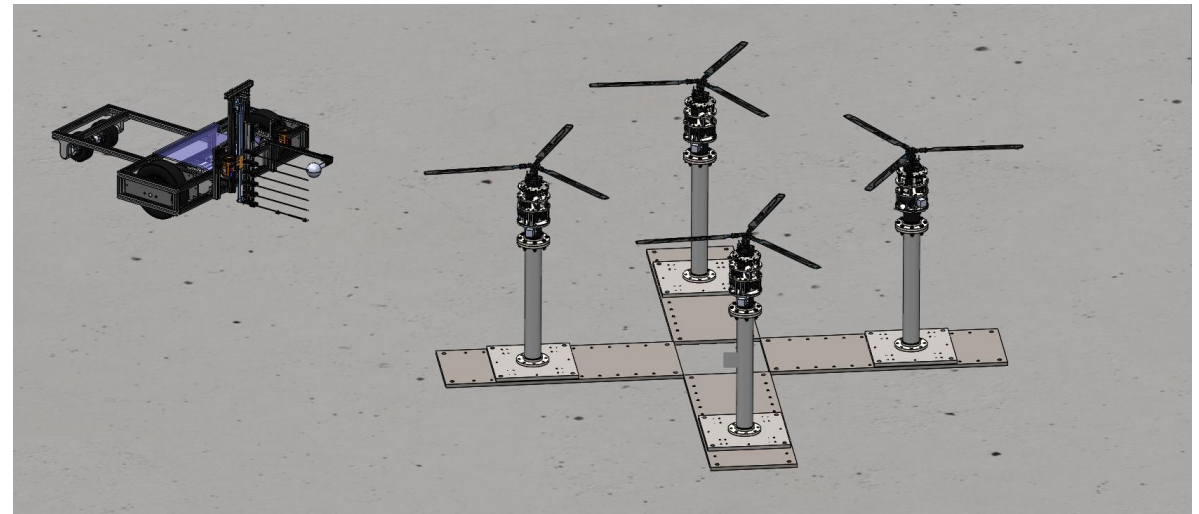
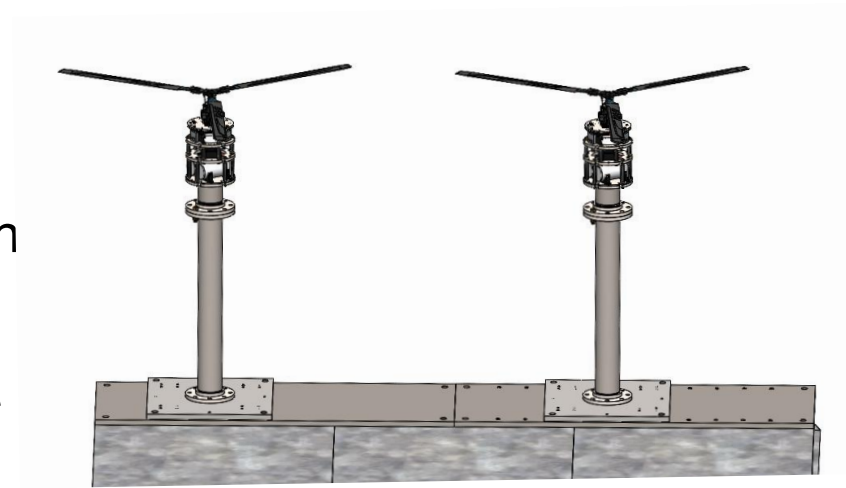

Outwash Rotor



- Rotor, hub, swashplate, transmission, motor all from SAB Goblin 700S R/C Helicopter
- Rotor
 - 5 ft diameter, 3-blade, $\sigma=0.0755$
 - Untwisted blades, symmetric airfoil, ~12% t/c
 - Easily modified for reverse rotation
 - 2000 RPM maximum with closed loop control
- Swashplate for remote collective and cyclic control
- 3x uniaxial loadcells for thrust and moment measurement
- Performance
 - 40 lb thrust at 1600 RPM



Rotor Stand



- Interchangeable spools for variable rotor height
 - 2 to 10 ft (0.4D – 2D) in 0.5 ft increments

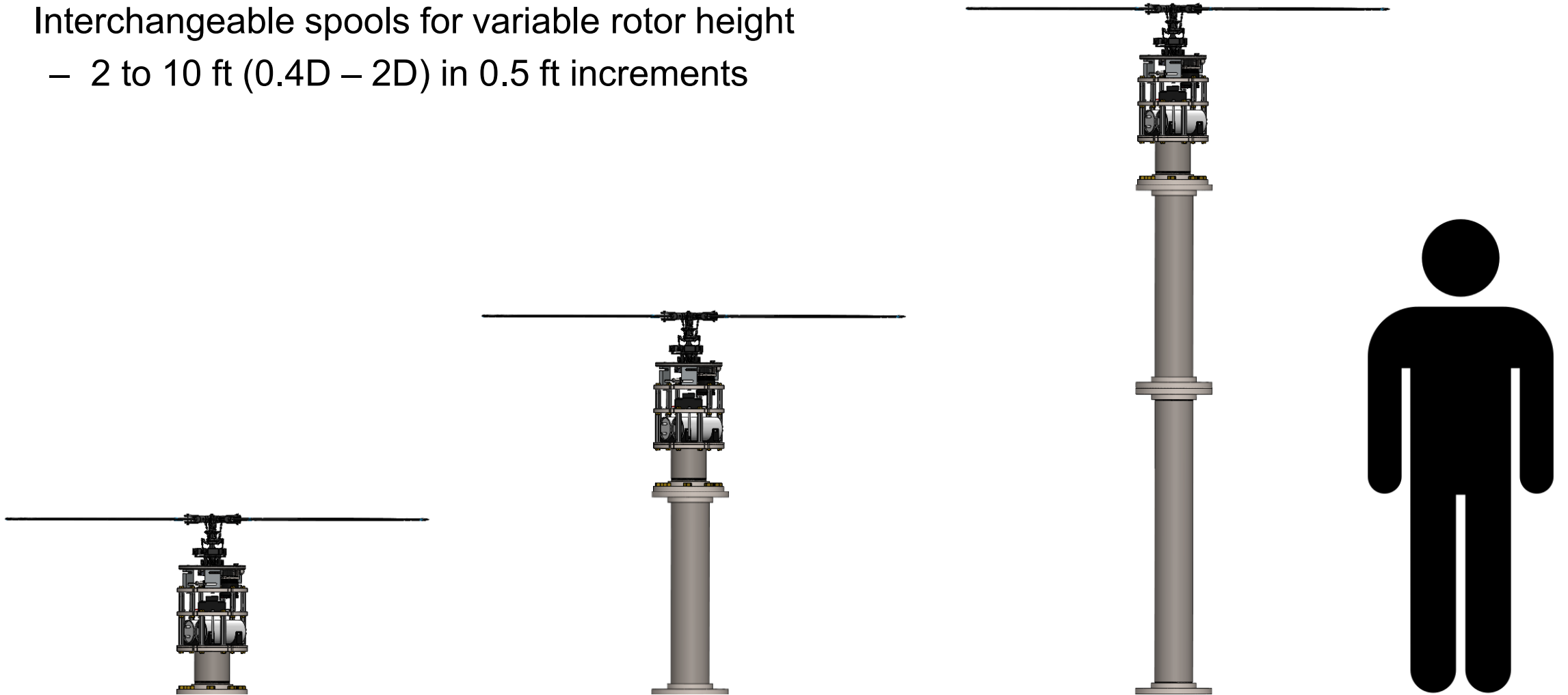

Instrumentation Cart

- Semi-autonomous linear travel
 - GPS position and direction within 0.25-in / 1°
- Vertical traversing rake
 - 6x single-wire hot films on 18-in probe supports
 - 1x TriSonica Sphere sonic anemometer
- Data acquisition system
 - Dantec 6-channel CTA, 10 kHz bandwidth
 - WiFi telemetry and control

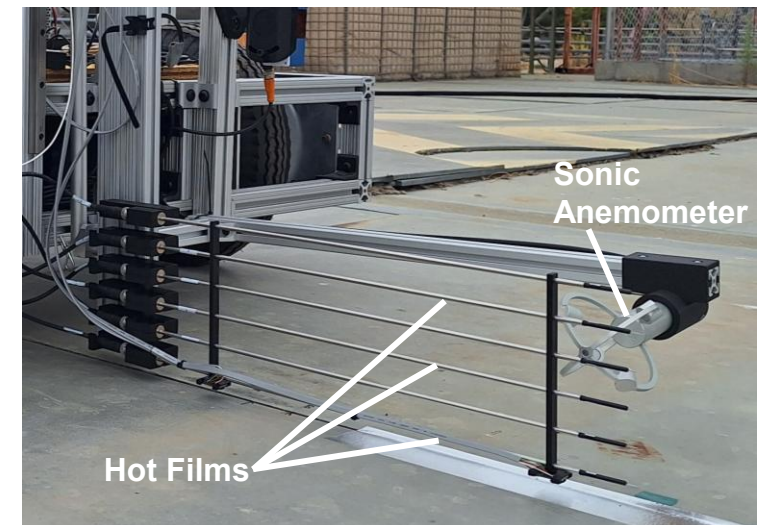
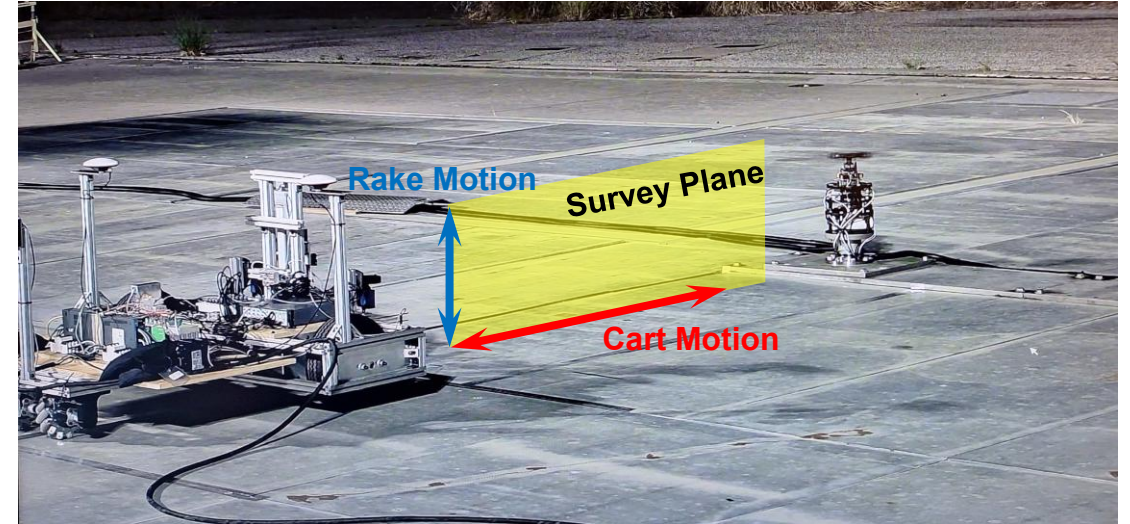

Schlieren Velocimetry



- New measurement technique developed in collaboration with DLR
- Helium is seeded into rotor outwash upstream of cart
- Camera captures Background Oriented Schlieren (BOS) pattern viewed through seeded flow
- Density gradient in seeded flow produces optical displacement of BOS background features
- Post-processing software tracks density changes between consecutive frames to deduce velocity

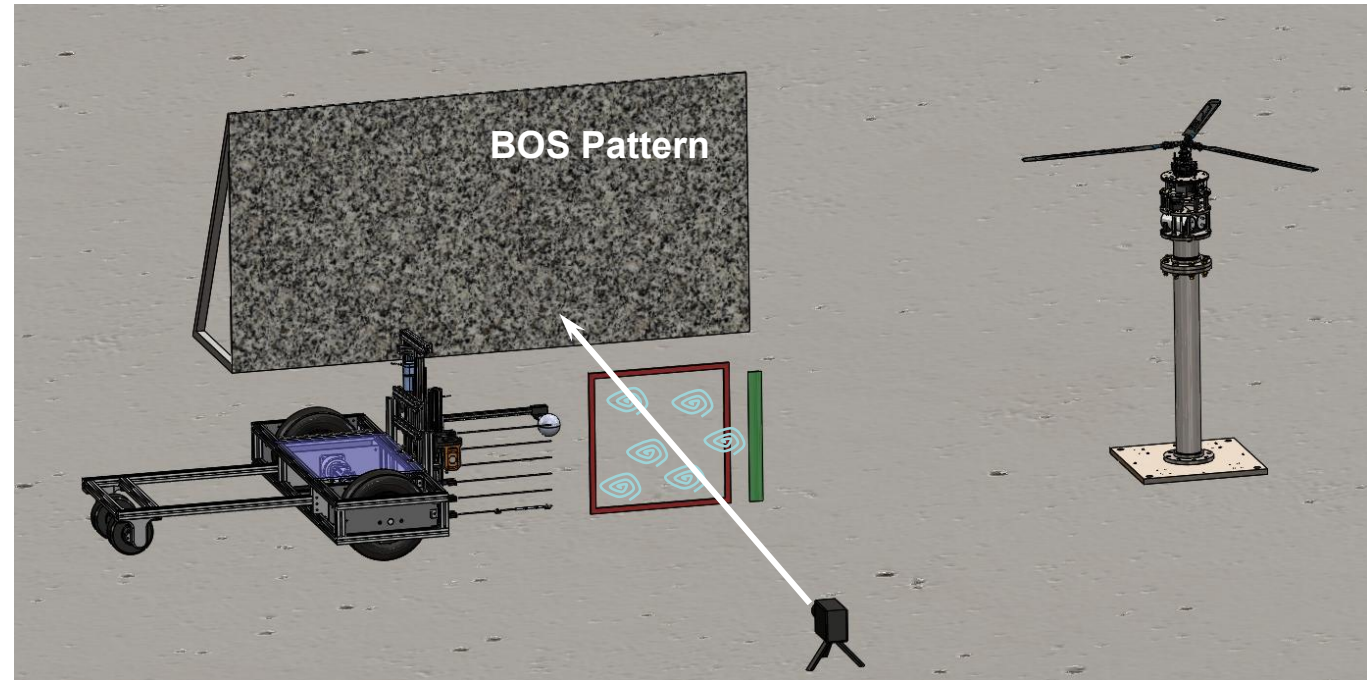

Test Conditions

- The test was conducted at the Outdoor Aerodynamic Research Facility (OARF) at NASA Ames Research Center
- Stand and Cart

Parameter	Value
Stand Heights	0.4, 0.6, 1.0, 1.4 D
Cart Positions	0.6–4.0 D
Hot Film Positions	0.5–13.63 in (0.63 in increment)

- Rotor Trim

Parameter	Value
Rotor Speed	1200, 1600
C_T/σ	0.03, 0.05, 0.06, 0.09
Moment ^a	0, 40, 80 in-lb
Local Wind Speed	<2 ft/s

^a Measurement has been performed at the plane of 0, 45, 90 degrees

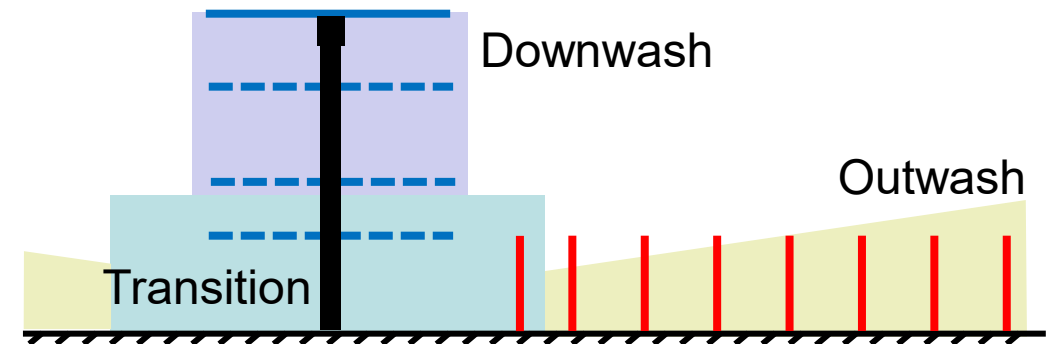

Sample Results



- Wall Jets
- Rotor height
- Cart distance
- Rotor thrust
- Hub moment
- Propagation Characteristics
- Schlieren Velocimetry



The Wall Jet Analogy

- M.B. Glauert (1956) characterized the flow along the wall using:
 - Maximum radial velocity, V_m
 - Wall jet half-height, $Z_{1/2}$
- Established $V_m \propto x^{-1/2}$ and $Z_{1/2} \propto x^{3/4}$
- Single rotor outwash is reminiscent of normal, axisymmetric wall jet flow

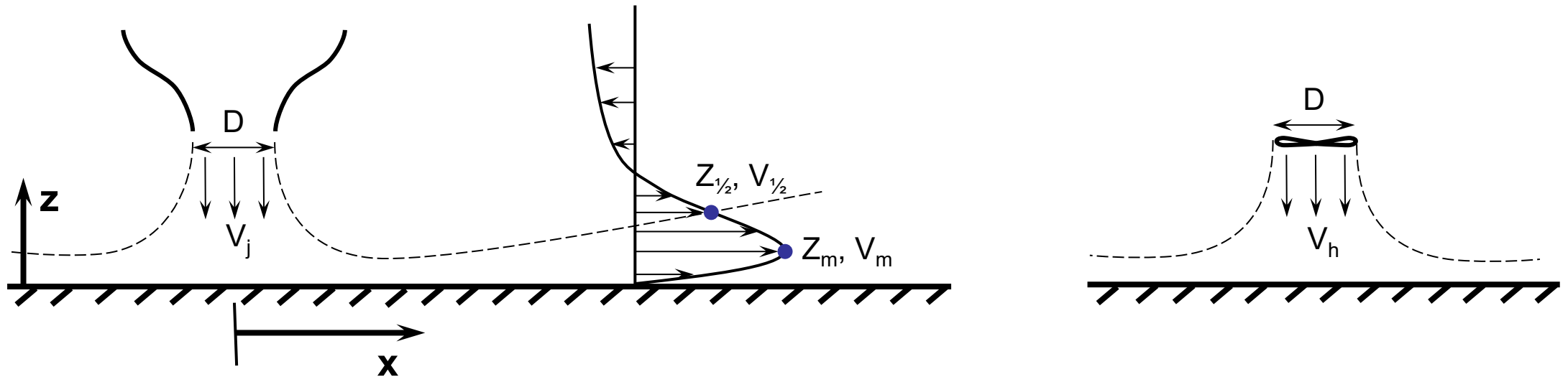

Effects of Rotor Height and Cart Distance



$CT/\sigma = 0.06$, Zero moment
 $r/D = 2.0 D$

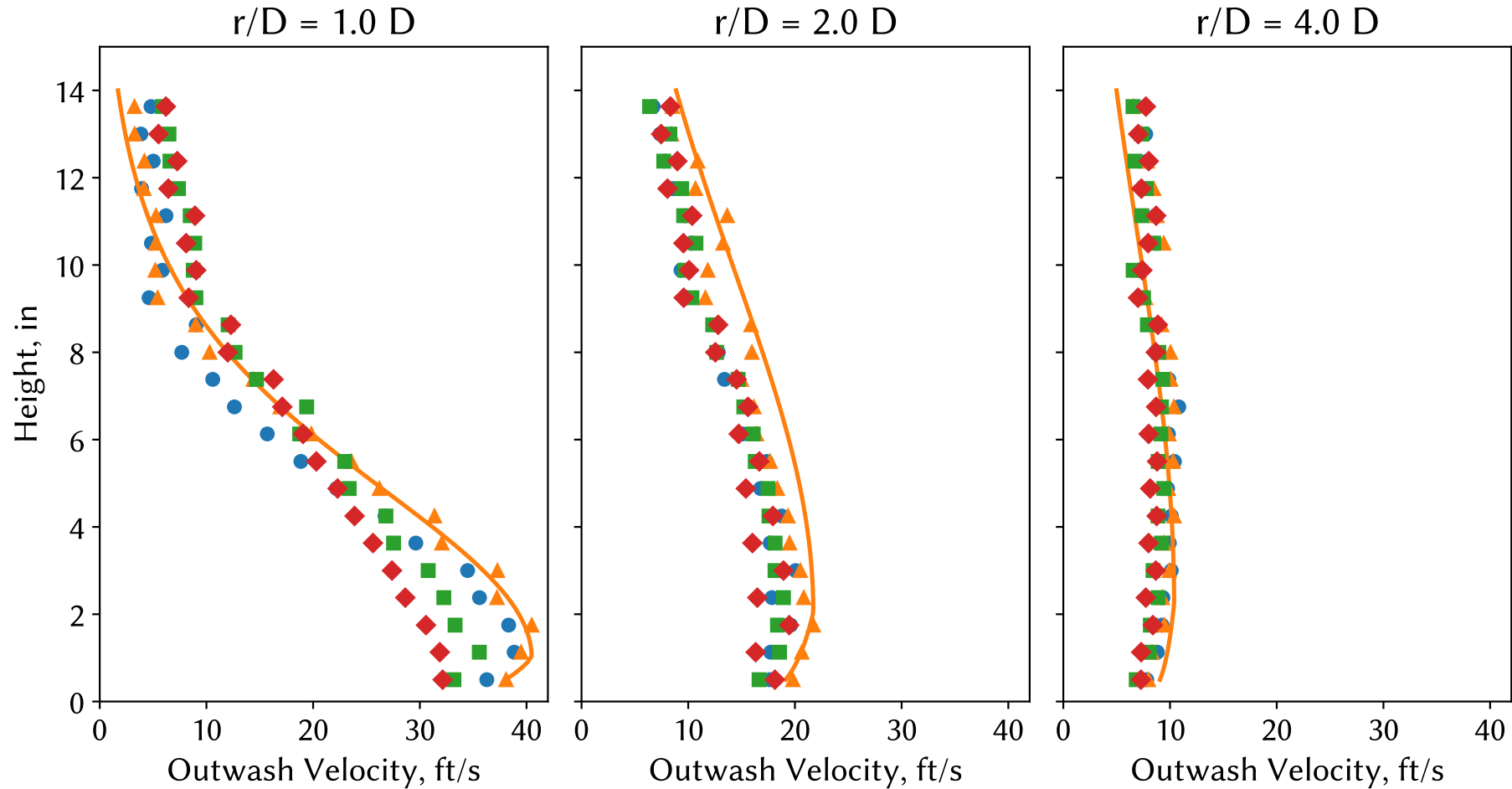

Measured Wall Jet Parameters



$CT/\sigma = 0.06$, Zero moment

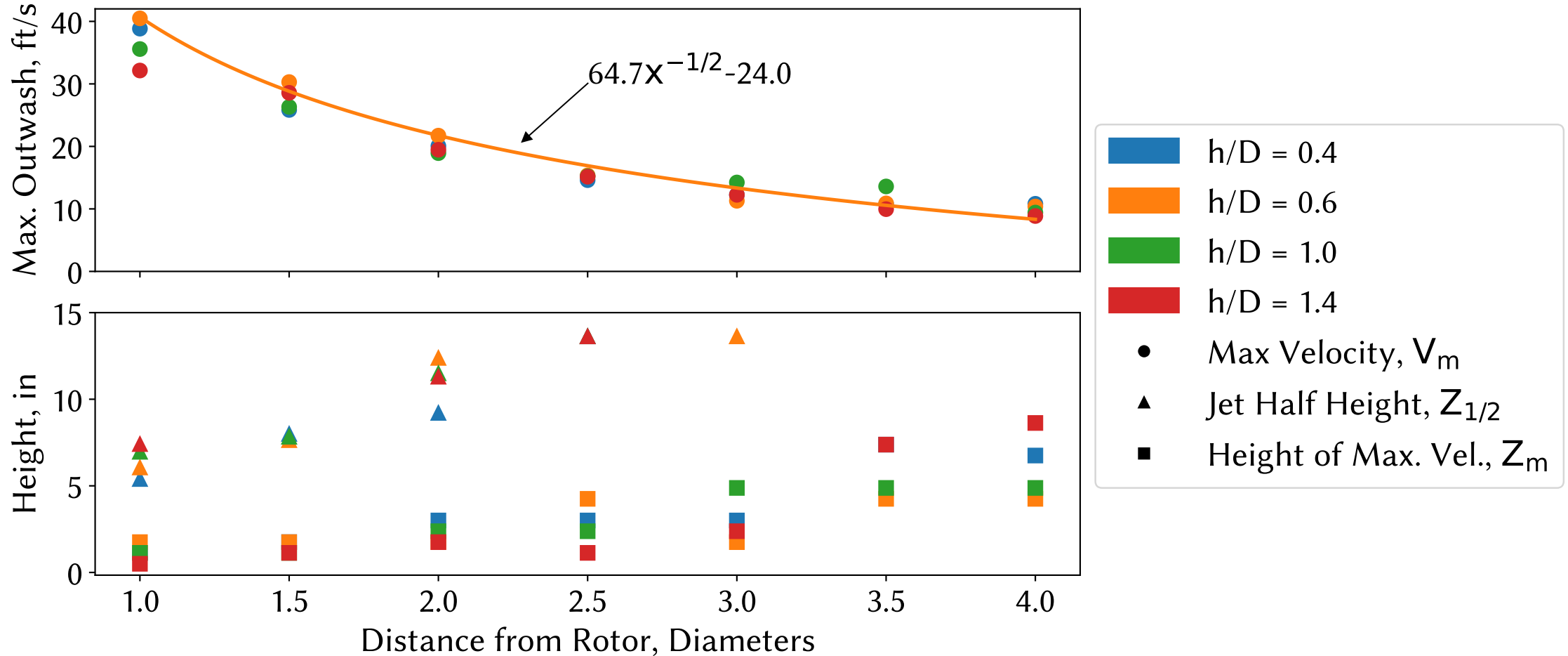

Thrust Effects on Outwash



$h/D = 0.4$, $r/D = 1.0$, 1600 RPM, No Moments

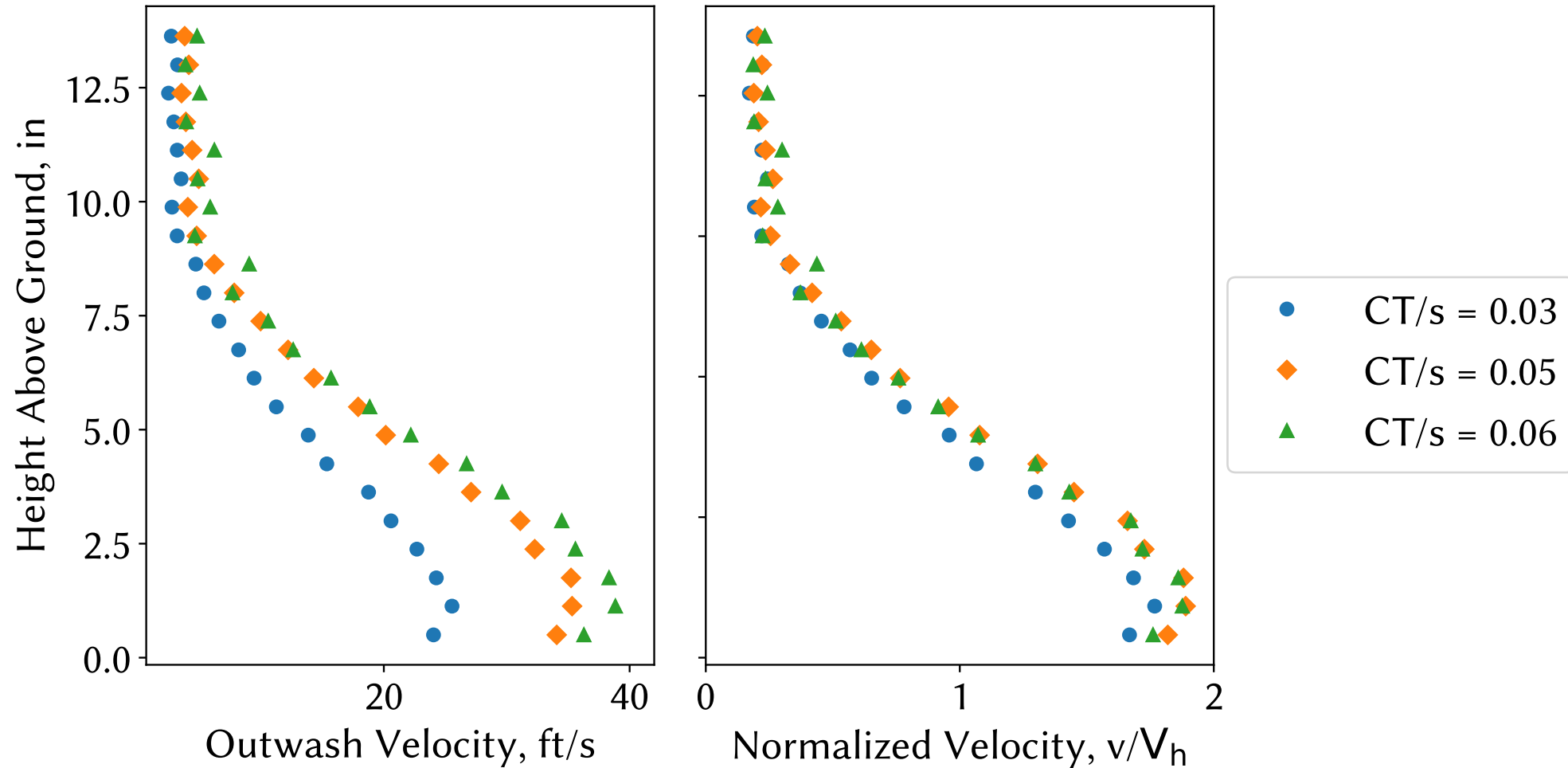

Moment Effects on Outwash

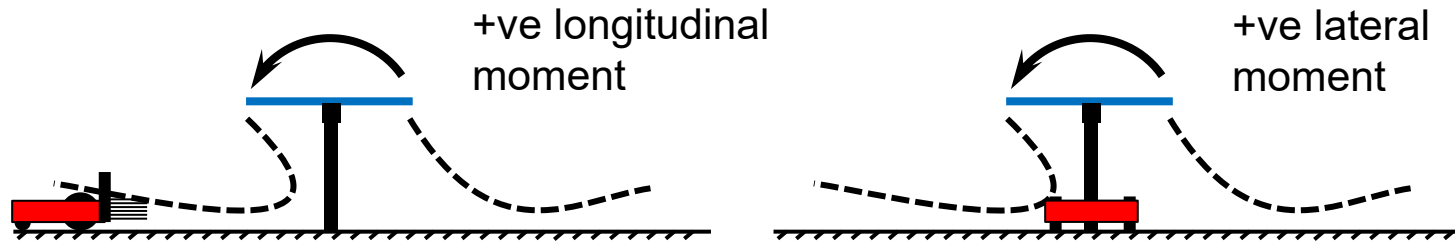

$h/D = 1.0, r/D = 1.5, T = 40 \text{ lb.}$

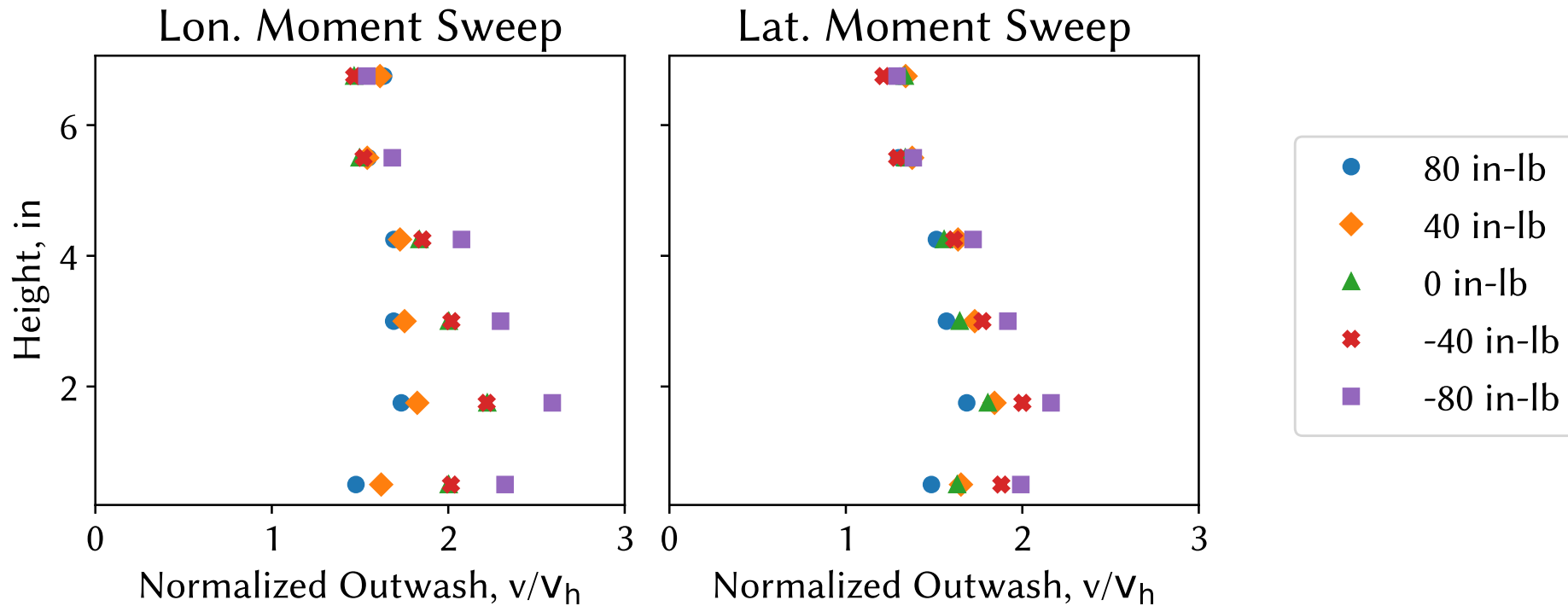



Outwash Propagation Characteristics

$$h/D = 1.0, C_T/\sigma \sim 0.02 \rightarrow 0.09, V_h \sim 9 \rightarrow 18 \text{ ft/s}$$

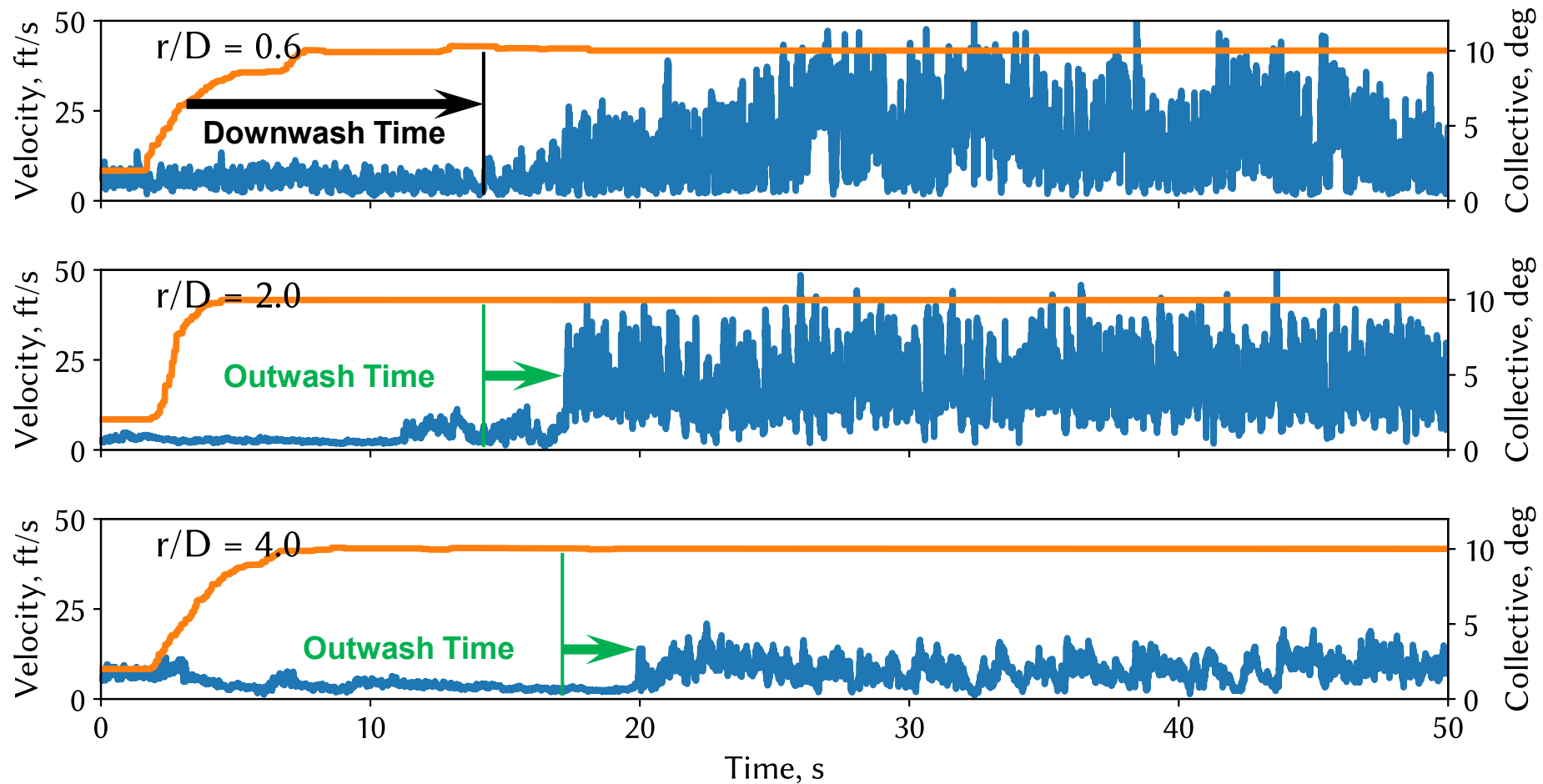

Schlieren Velocimetry

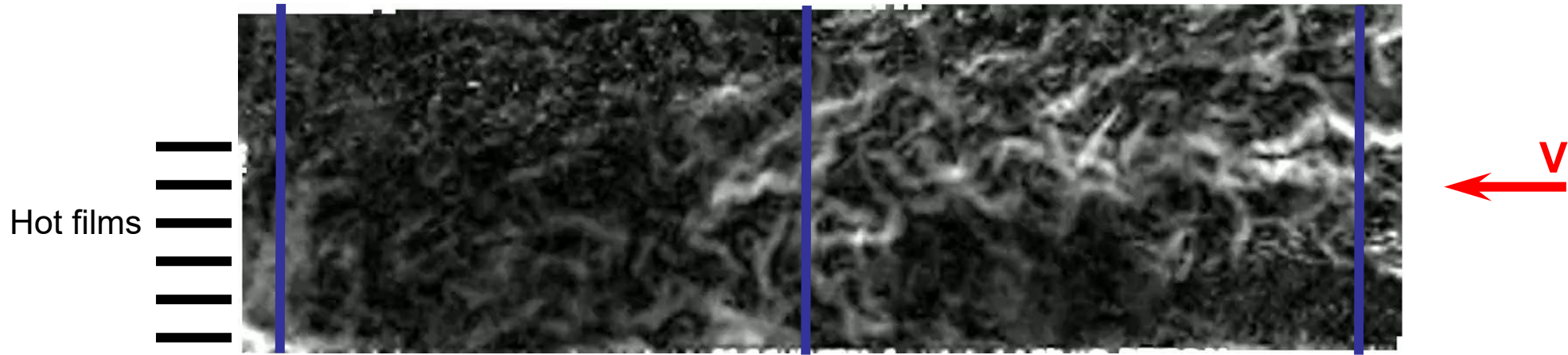

$r/D=2.0$

$r/D=1.8$

$r/D=1.6$

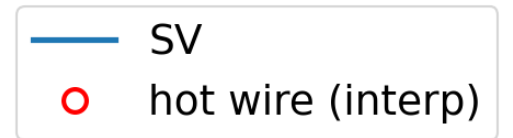
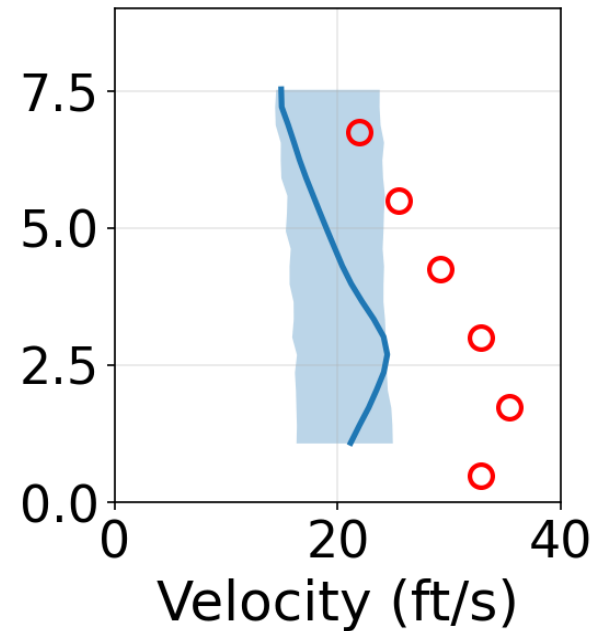
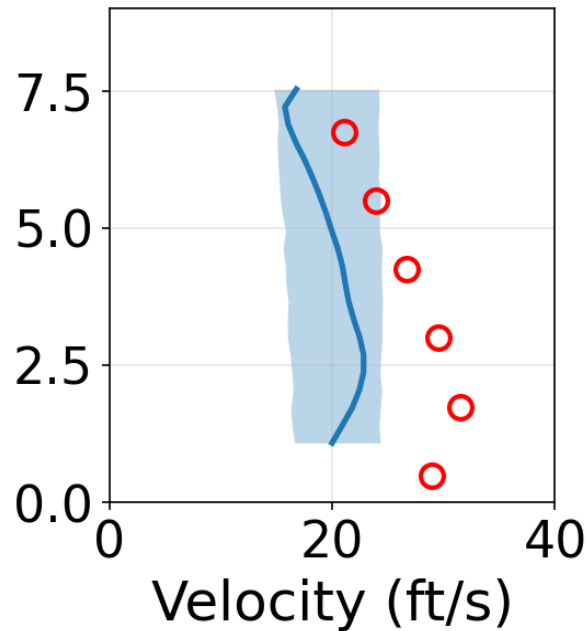
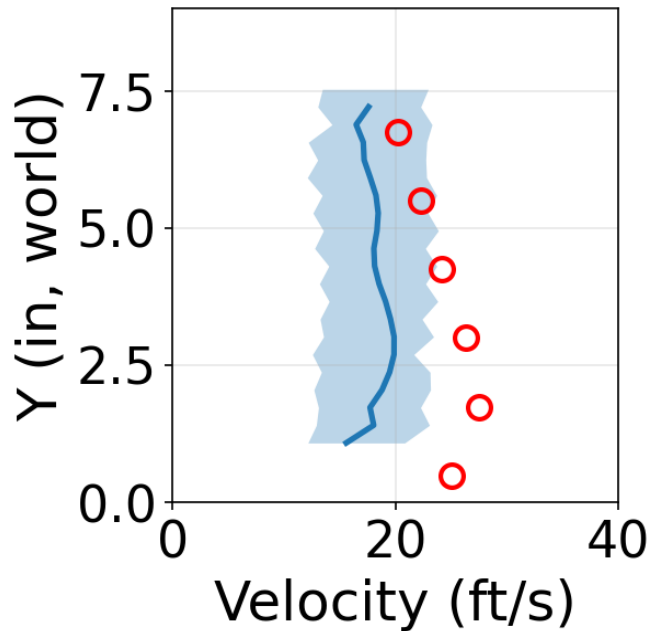

Summary



- Completed outwash measurements for a single rotor in hover
- Increasing rotor height provides modest relief of outwash velocity
- The wall jet is a useful model for outwash characteristics at a distance from the rotor
- Hover induced velocity is an effective predictor of peak outwash velocity
 - Peak outwash velocity near the rotor will approach $2V_h$
- Rotor trim significantly changes outwash velocity
- Downwash propagation time is much longer than outwash propagation time

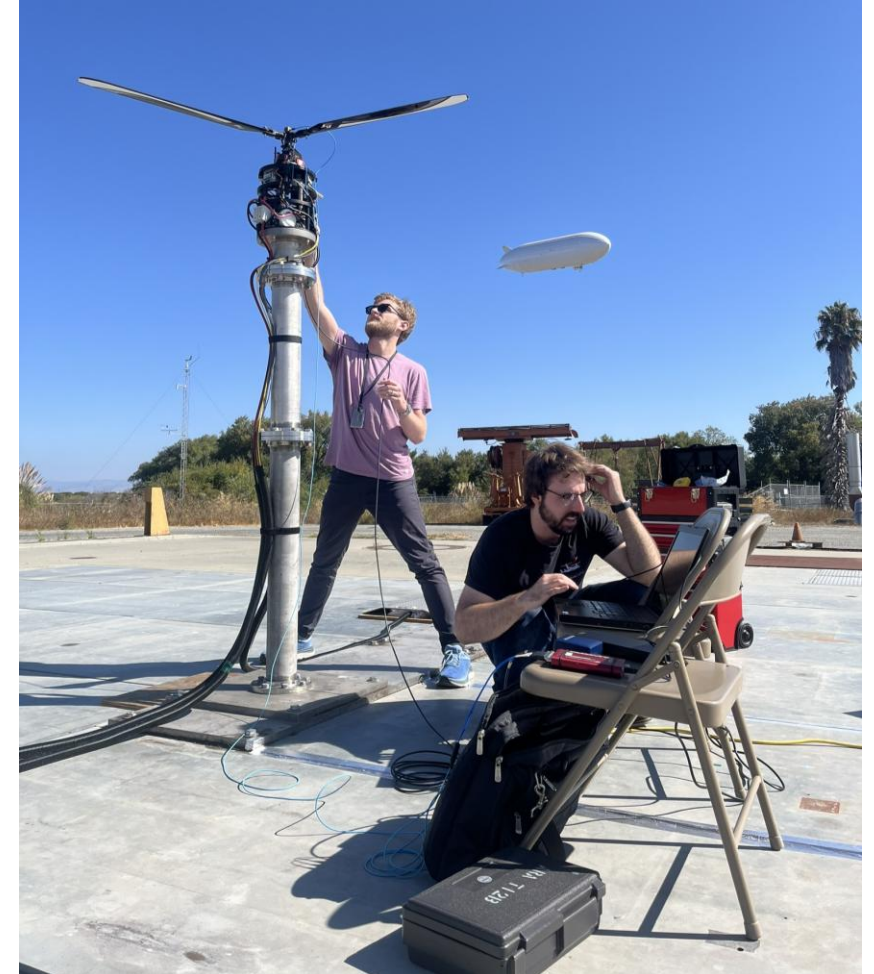

Future Work and Ideas

- Phase 1—Single Rotor
 - Publish data as a NASA Technical Report
- Phase 2—Dual Rotor
 - Examine the effects of interacting rotor wakes on outwash - 2026
- Phase 3—Quad Rotor
 - Explore outwash characteristics unique to eVTOL aircraft
- Additional Ideas
 - Wing and fuselage effects
 - Vertiport interactions
 - External collaboration

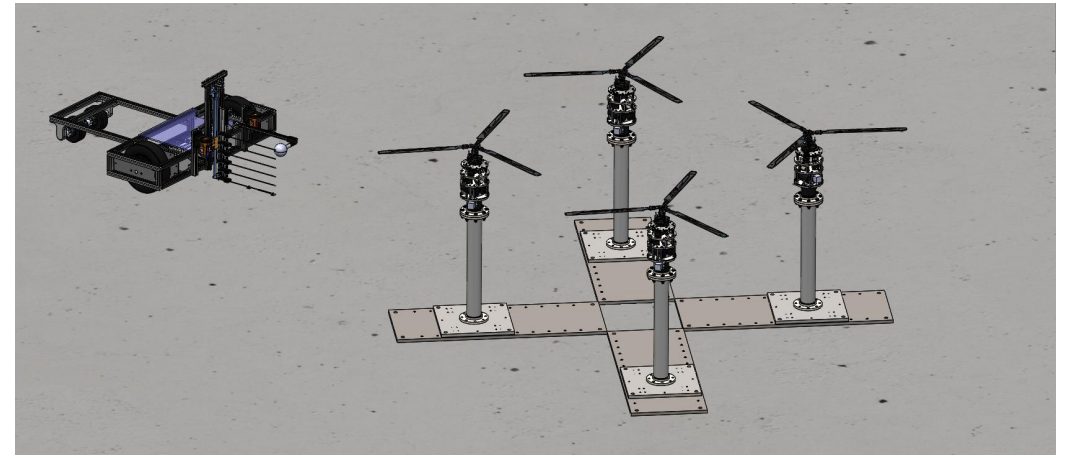
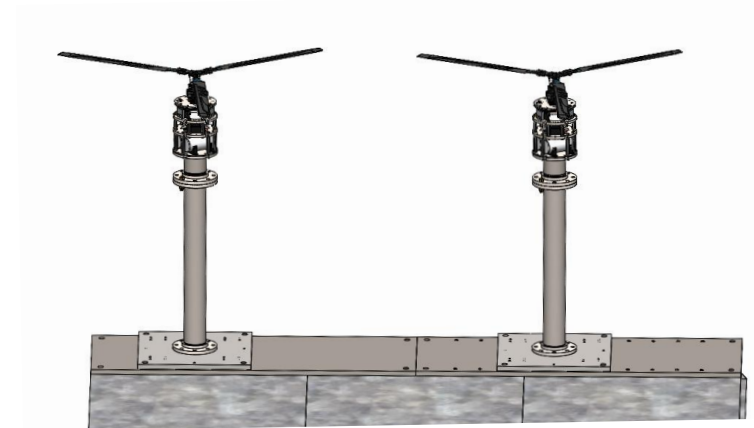

Questions

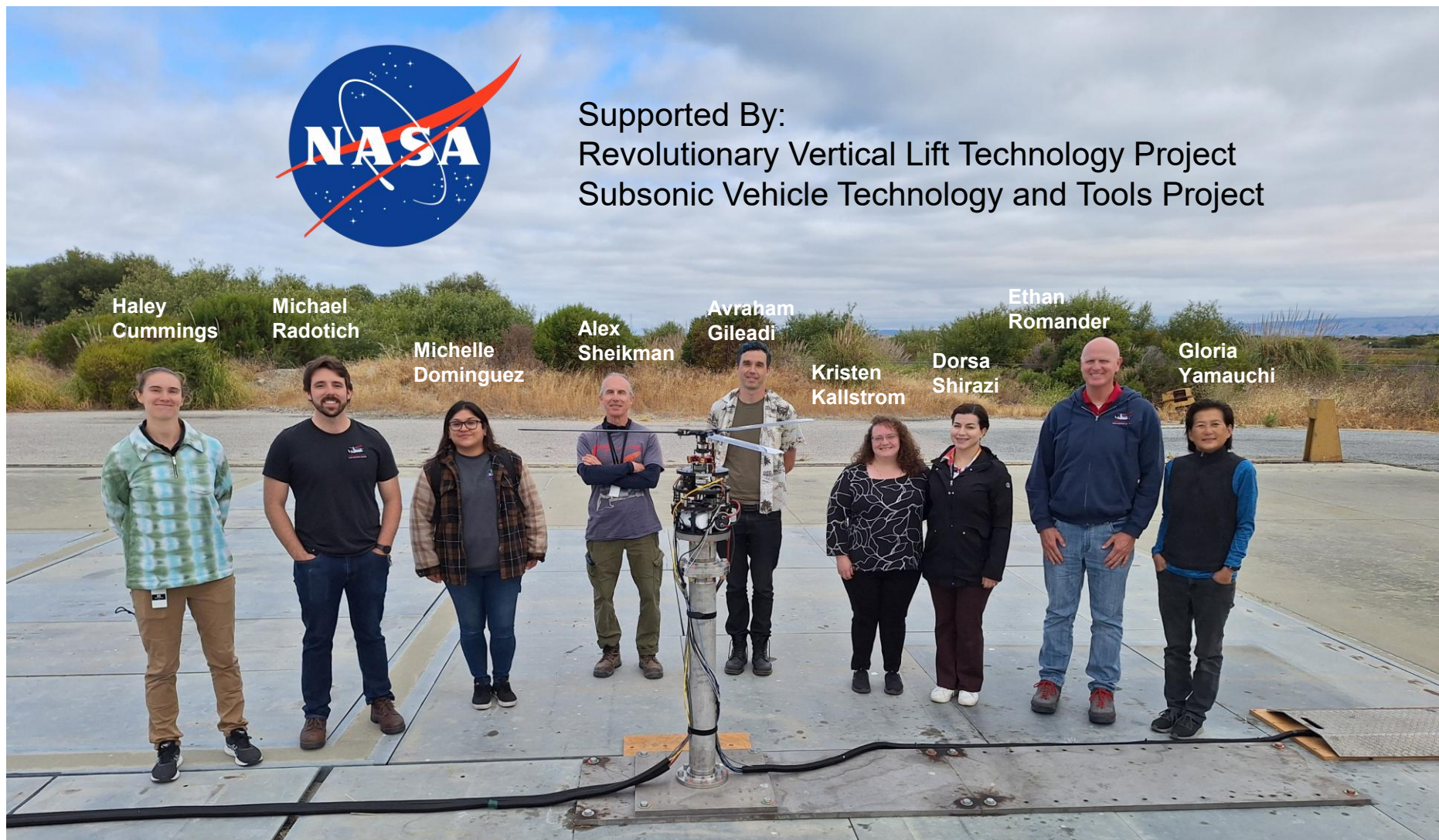
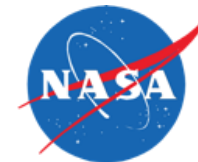



Backup

Outwash Spectral Content



All Hot Films, $h/D = 0.4$, $C_T/\sigma = 0.06$

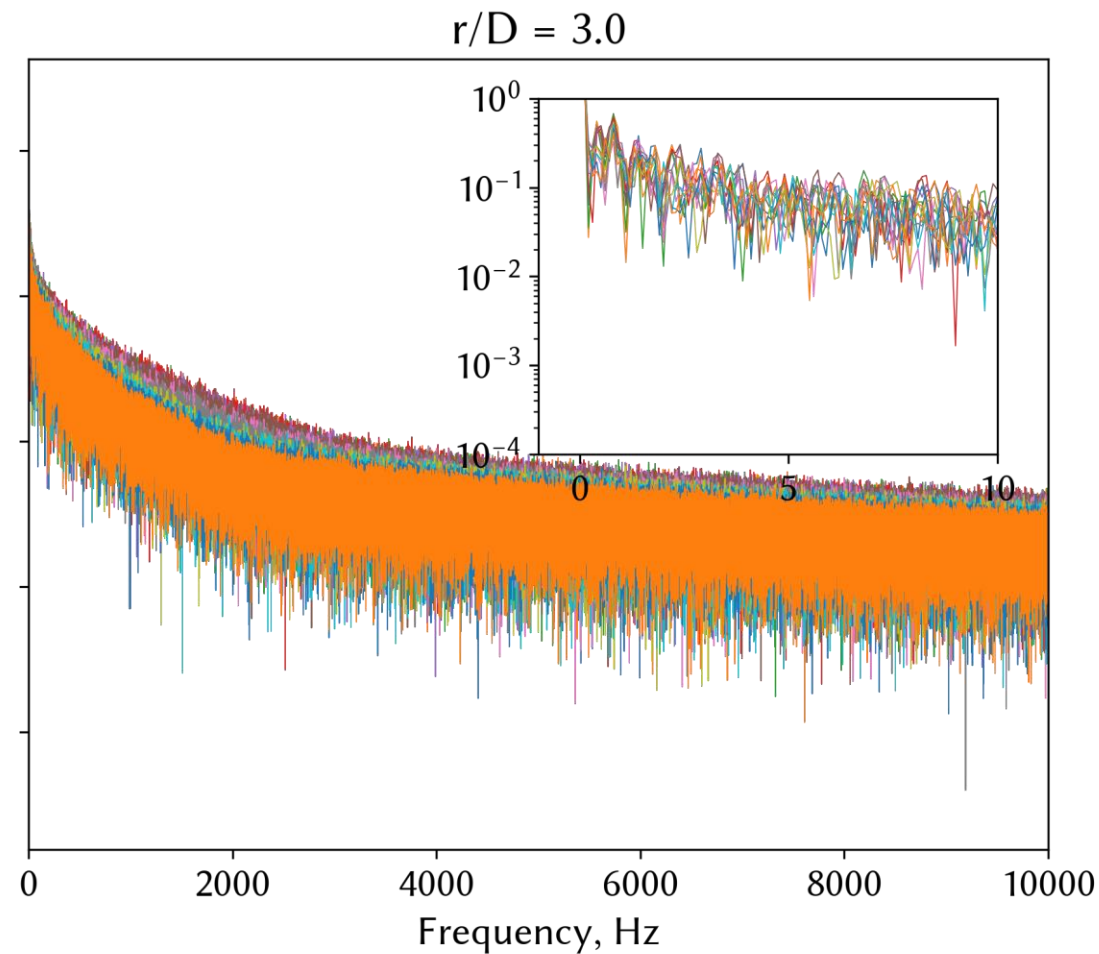
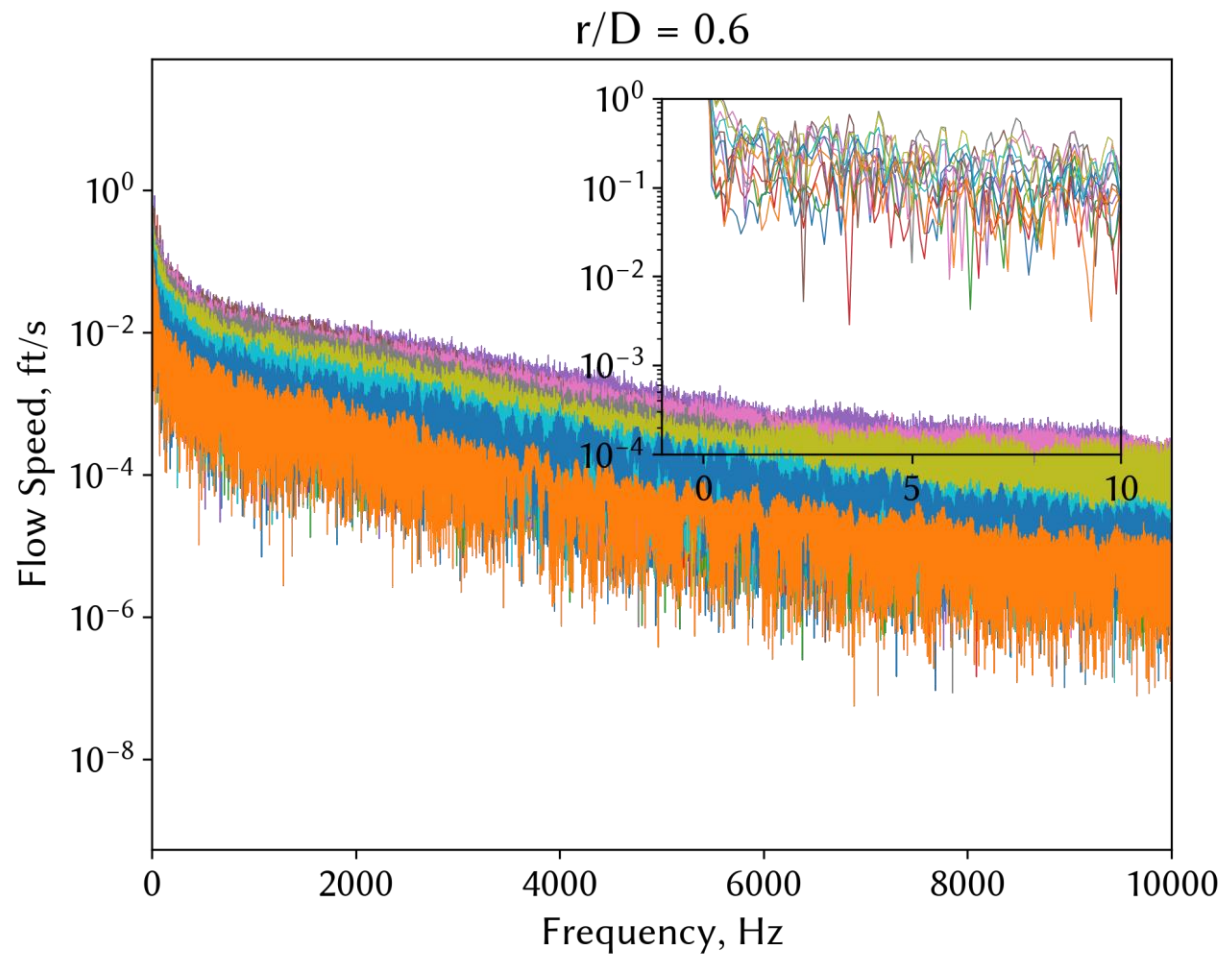

Outwash Spectral Content

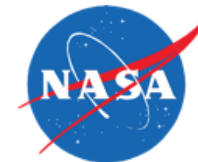

All Hot Films, $h/D = 1.0$, $C_T/\sigma = 0.06$

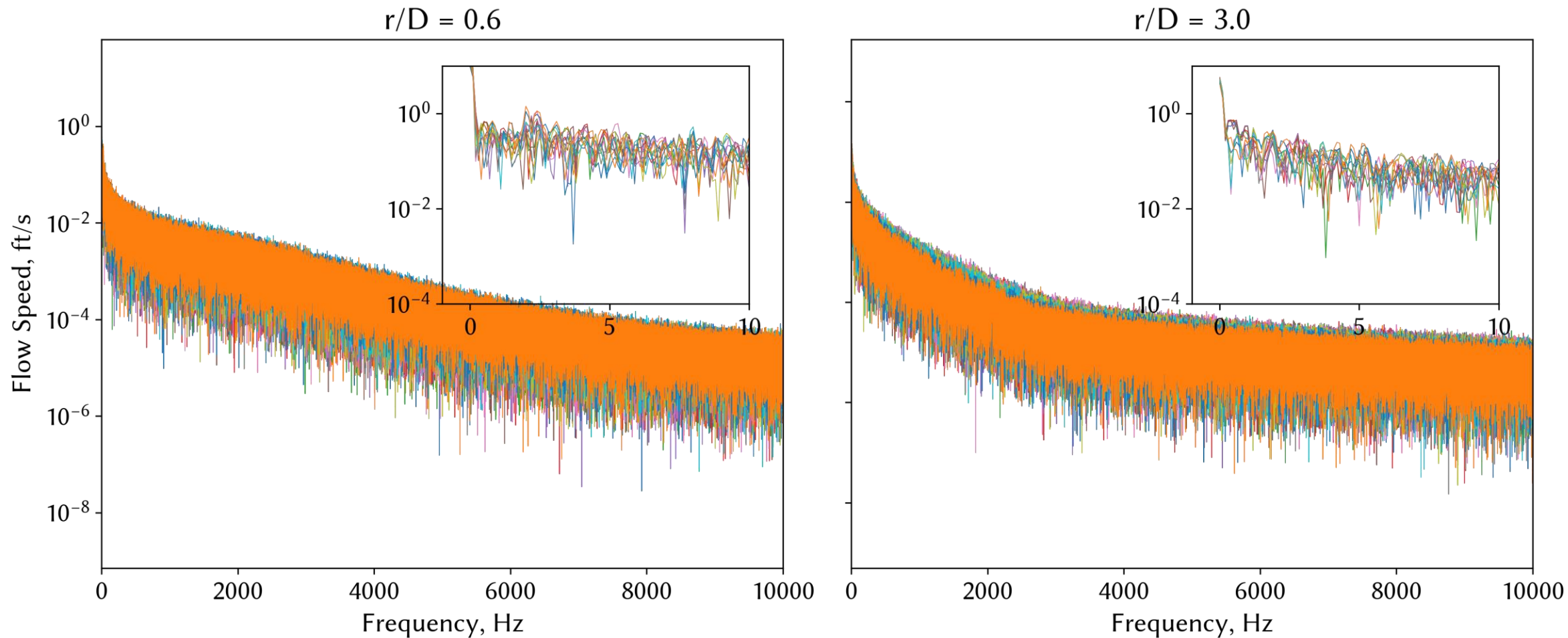

Effects of Rotor Height and Observer Distance



$CT/\sigma = 0.06$, Zero moment

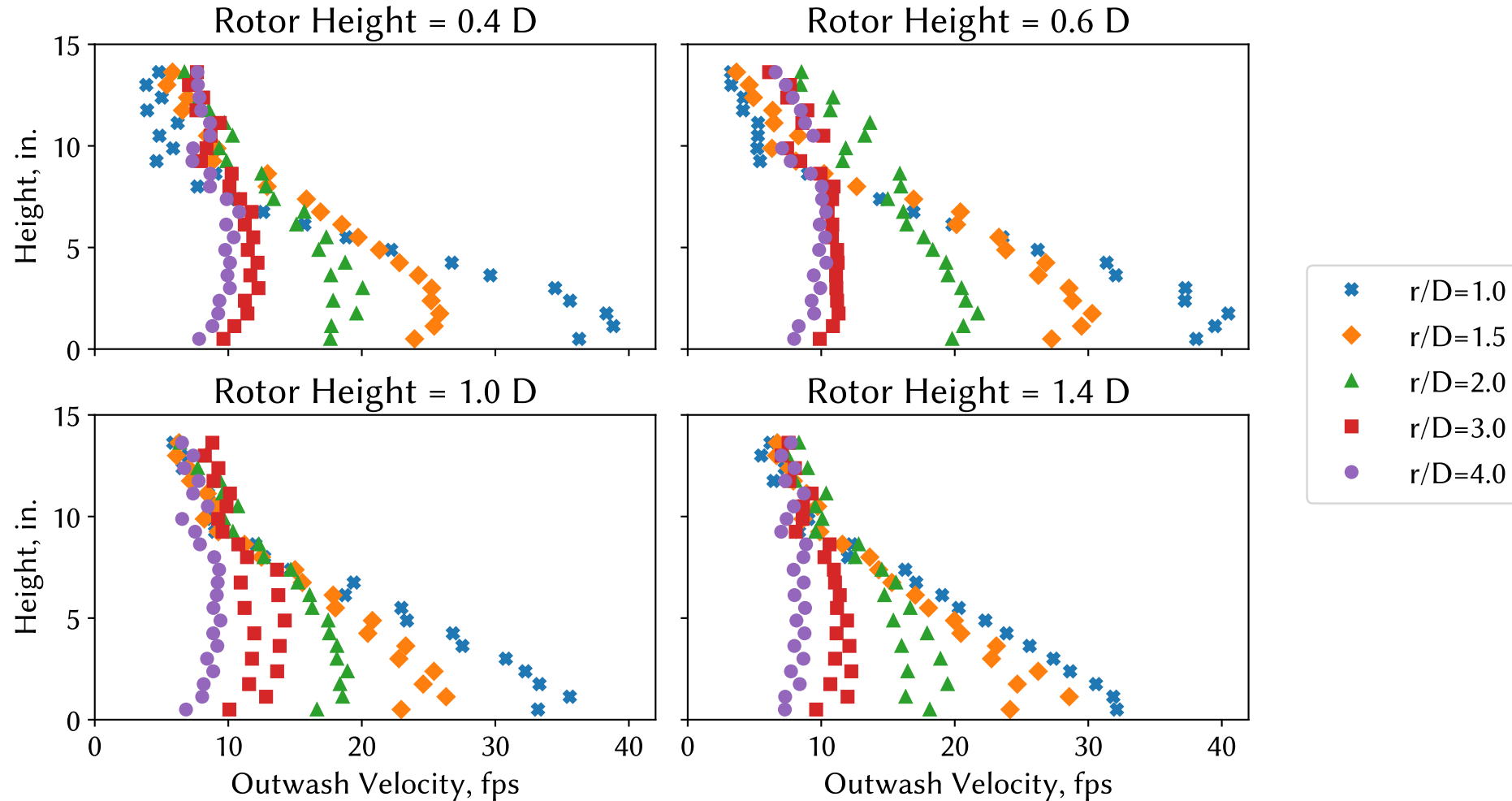

Moment Effects on Outwash

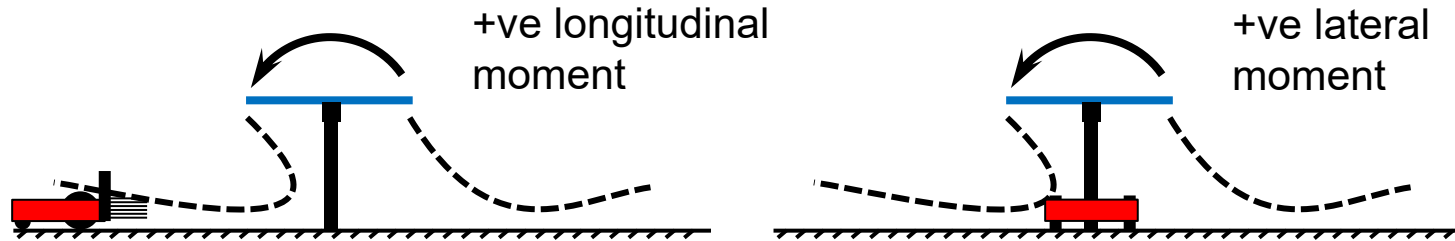

$h/D = 0.6$, $r/D = 1.5$, $T = 40$ lb.

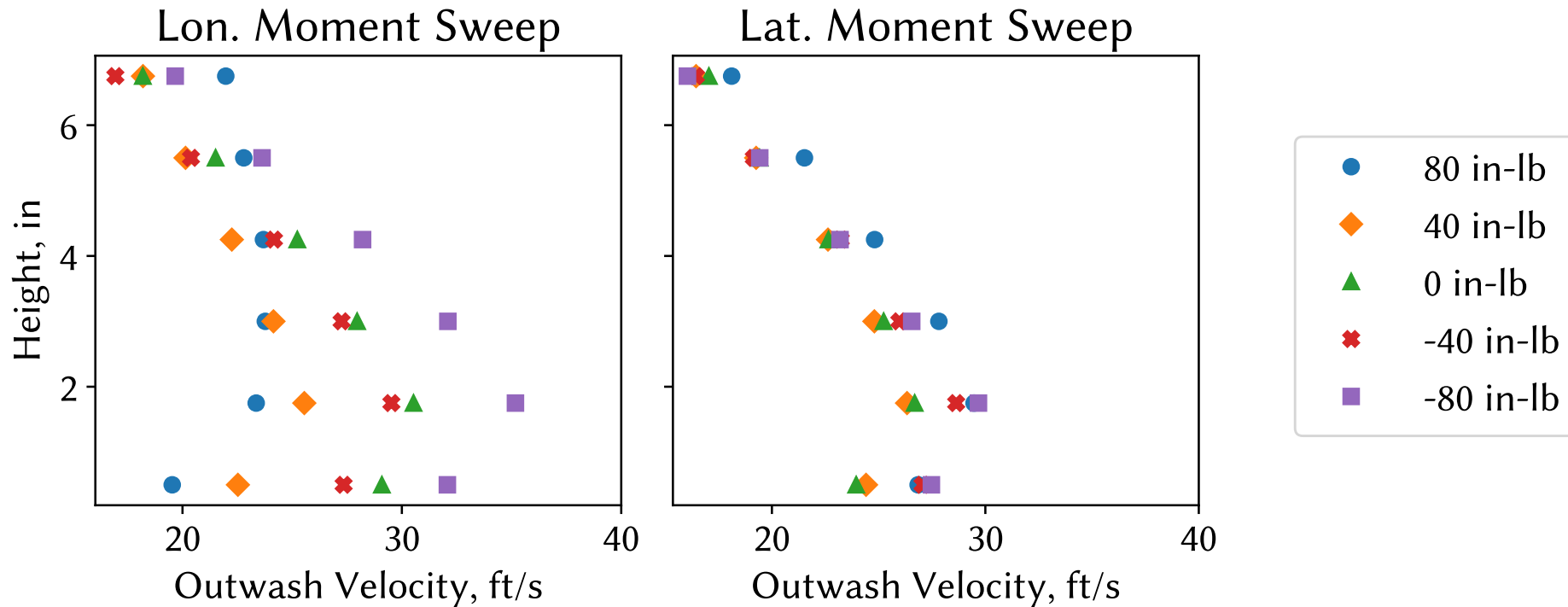



Outwash Propagation Characteristics

$h/D = 1.0, C_T/\sigma \sim 0.02 \rightarrow 0.09, V_h \sim 9 \rightarrow 18 \text{ ft/s}$

